

General Purpose Machine Bases and Workstation Frames

- Available in kit form or assembled
- Includes Standard Adjustable Leveling Feet
- Casters or Anchor Brackets Available on Request
- Choice of Light, Standard, or Heavy Duty
- Enclosure Panels Available on Request
- Overhead Light Fixture or Overhead Tool Hanger available
- Sweep Height is 6"
- Custom Tops Available
- Custom Sizes Available

Custom Workstation Base with Optional
Overhead Mounting

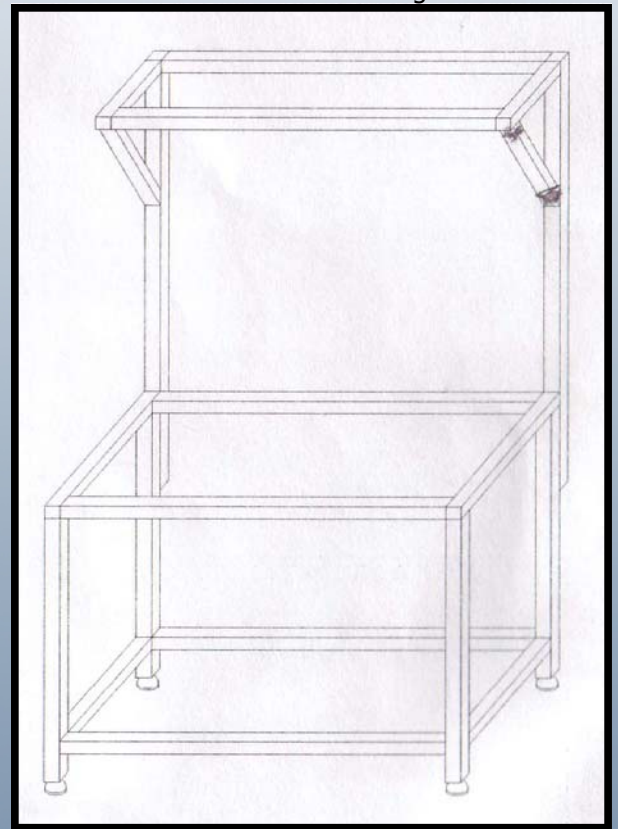

Standard Machine/Workstation Base

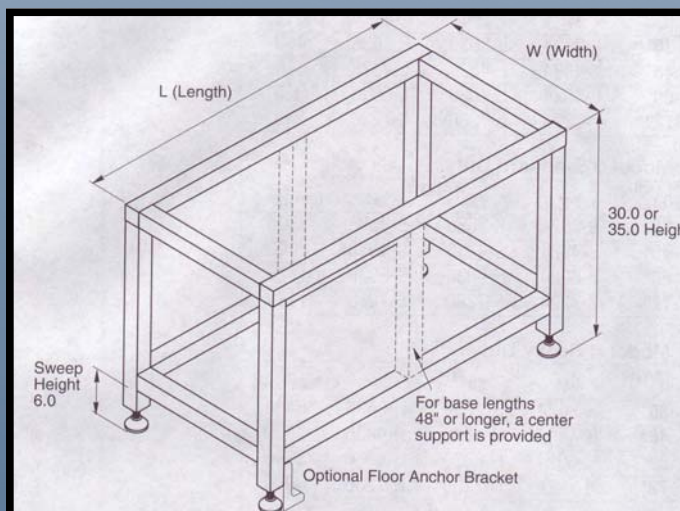

Custom Workstation Base with Optional
Butcher Block Top



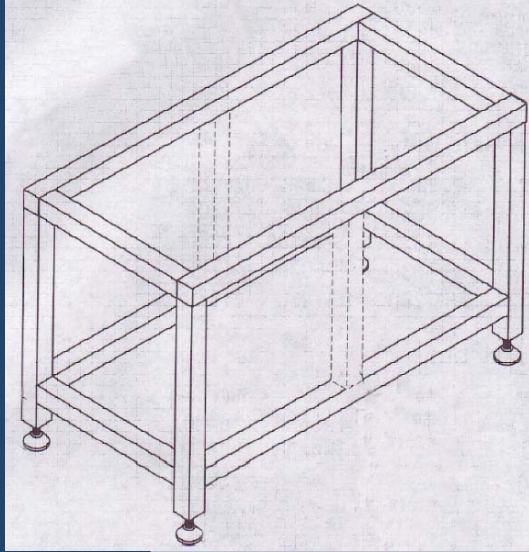

Standard Base Model L Light Duty

Length (L)	24"	30"	36"	Max Load
36"	L-3624	L-3630	L-3636	400 lbs.
48"	L-4824	L-4830	L-4836	360 lbs.
60"	L-6024	L-6030	L-6036	300 lbs.
72"	L-7224	L-7230	L-7236	240 lbs.

Standard Base Model S Standard Duty

Length (L)	24"	30"	36"	Max Load
36"	S-3624	S-3630	S-3636	2800 lbs.
48"	S-4824	S-4830	S-4836	2000 lbs.
60"	S-6024	S-6030	S-6036	1720 lbs.
72"	S-7224	S-7230	S-7236	1480 lbs.

Standard Base Model H Heavy Duty

Length (L)	24"	30"	36"	Max Load
36"	H-3624	H-3630	H-3636	5400 lbs.
48"	H-4824	H-4830	H-4836	3800 lbs.
60"	H-6024	H-6030	H-6036	3300 lbs.
72"	H-7224	H-7230	H-7236	3000 lbs.

Standard Base Ordering Example

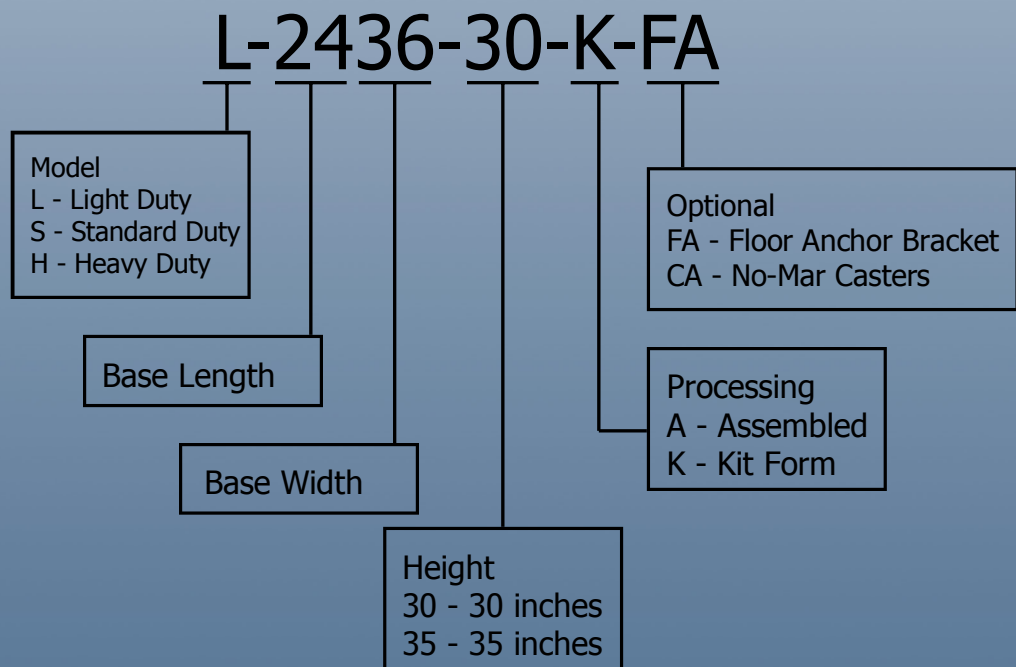

30" x 72" x 1 3/4" Butcher Block Tops in Stock